

Installation Manual

L.TRA.VA.C.M

Ford Transit 80/120 (1989—2000)





Ford Transit 80/120
L.TRA.VA.C.M

CONTENTS

1. FOREWORD	3
2. INTRODUCTION	4
3. VERY IMPORTANT NOTES.....	5
4. INSTRUCTIONS FOR INSTALLATION	7
4.1. Removal of Bump Stop and Attachment of Upper Bracket	7
4.2. Attachment of Lower Bracket.....	7
4.3. Preparation of the Air Spring	7
4.4. Installation of Air Spring	8
4.5. Fitting of Inflator Console.....	9
4.6. Tube Connection and Disconnection, Cutting and Routing	10
4.7. Spring Inflation.....	11
4.8. Spring Alignment	12
4.9. Maintenance.....	12
5. INSTALLATION DIAGRAMS.....	13
6. EPILOGUE	17

DSC Nederland B.V.
Het Wegdam 22
7496 CA Hengevelde
Nederland
Tel. +31 (0)547 33 30 65
Fax. +31 (0)547 33 30 68

www.dunlopsystems.nl

© 2017, DSC Nederland B.V.



Ford Transit 80/120
L.TRA.VA.C.M

1. FOREWORD

This manual provides instructions for the installation of an auxiliary air suspension kit, developed specifically for the Ford Transit 80/120 (1989—2000). To ensure correct installation of the kit, it is strongly recommended that these instructions are read thoroughly before commencing any installation work. Installation should only be carried out by a suitably qualified mechanic or specialist installation facility. DSC Nederland will not accept any responsibility for faults or defects arising from incorrect installation, which automatically renders the guarantee invalid.

IMPORTANT : Manufacturer's Declaration Form

A manufacturer's declaration form is provided with your kit. Following installation of the kit please ensure that this form is completed, signed by a qualified fitter and a copy is returned to DSC Nederland by post, fax or e-mail. Our e-mail address is: info@dunlopsystems.nl



Ford Transit 80/120 L.TRA.VA.C.M

2. INTRODUCTION

Thank you for choosing an auxiliary air suspension kit from the range offered by *DSC Nederland*. Auxiliary air suspension is fitted in tandem with the standard steel springs of the vehicle suspension, and provides enhancements in terms of both the stability of the vehicle and the comfort of the passengers...

Vehicle Levelling

Simply by varying the air pressure in the springs, the vehicle can be levelled both front-to-rear and side-to-side. Keeping the vehicle level optimises stability, ensures correct headlamp beam distribution and reduces tyre wear arising from uneven distribution of weight.

Straight Line Stability

Straight line stability is greatly increased at higher speeds, and when subjected to buffeting from cross-winds or large overtaking vehicles.

Reduced Body Roll

Body roll when cornering or negotiating roundabouts is significantly reduced.

Fatigue Reduction and Wear Compensation

Suspension fatigue is reduced, so helping to prevent leaf springs from sagging under repeated or constant loading. Any sagging already present can be compensated-for. This is a particular benefit for motorhomes, which are always fully laden.

Ride Comfort

Air springs help to absorb shock loads from uneven road surfaces, therefore general ride quality is much improved.

Ford Transit 80/120
L.TRA.VA.C.M

3. VERY IMPORTANT NOTES



Gross Vehicle Weight (GVW)

Air assist kits are not in themselves designed to increase the gross vehicle weight (GVW) rating of a vehicle. They do not legally allow for carriage of a load greater than the carrying capacity stated on the data plate of the vehicle.

Do not exceed the maximum load specified by the vehicle manufacturer...

- ◆ to avoid compromising passenger safety
- ◆ to prevent possible damage to the vehicle
- ◆ for legal reasons



Load Sensing Valve (LSV) Adjustment

If your vehicle is not fitted with an antilock braking system (ABS) then it will have a load sensing valve (LSV) to automatically adjust braking force under varying load conditions. This valve **must** be adjusted immediately after the fitting of an air assist kit and before the vehicle is driven again on public roads.

If the LSV is not adjusted following the fitting of an air assist kit, it may misjudge rear load conditions to the extent that the braking pressure applied to the rear brakes is not correct (e.g. the rear wheels may lock with no load on the rear axle). The consequences of this in terms of vehicle stability and safety are potentially serious.

Vehicle Upgrading

Despite the above words of caution, it is possible to upgrade the weight rating of your vehicle. This must be carried-out by a specialist supplier that will...

- ◆ carry out any necessary modifications in addition to fitting the air assist kit
- ◆ complete documentation as necessary to inform the Vehicle and Operator Services Agency (VOSA) – a mandatory requirement
- ◆ supply and fit a new weight plate to replace the original plate supplied with the vehicle

This process applies to United Kingdom registered vehicles. The process in other countries may be different.



Ford Transit 80/120

L.TRA.VA.C.M

Safety Guidance Note

The following very useful guidance note is available for free download from the *Health and Safety Executive* (HSE)...

PM85, July 2007 *Safe recovery (and repair) of buses and coaches fitted with air suspension*

The uniform resource locator (URL) for this document is...

<http://www.hse.gov.uk/PUBNS/pm85.pdf>

Ford Transit 80/120
L.TRA.VA.C.M

4. INSTRUCTIONS FOR INSTALLATION



Preparation and Precaution

Before beginning installation, ensure that you have sufficient clearance between the axle and the chassis. Use a jack if necessary. Install at one side of the vehicle at a time.



Pay attention to your safety at all times during installation - always use axle stands to support the vehicle!



The following instructions make reference to the diagrams on pages 14 to 16 inclusive.

4.1 Removal of Bump Stop and Attachment of Upper Bracket

1. Unscrew and remove the bump stop—Figures 1, 2, 3 and 4
2. Attach the upper bracket to the chassis using a single M12 x 30mm bolt and associated washer, making use of the hole left vacant by removal of the bump stop. Be sure that the bracket is correctly oriented! Figures 5, 6 and 7.

4.2 Attachment of Lower Bracket

1. Place the lower bracket onto the axle, assuring correct orientation—Figures 8, 9 and 10
2. Attach the bracket to the axle using a single M10 x 110mm bolt, two washers and a locknut—Figures 11 and 12

4.3 Preparation of the Air Spring

1. Connect tubes to the air springs, making reference to Section 4.6. Use blue tubing for the left-side spring and black for the right-side.
2. Compress the springs and then bung the tubes to maintain the state of compression



Ford Transit 80/120

L.TRA.VA.C.M

4.4 Installation of Air Spring

1. Place the air spring onto the lower bracket and attach the lower plate of the spring to the lower bracket using two M8 x 16 bolts and two M8 washers—Figures 13 and 14. Do not fully tighten the bolts as yet.
2. Pass the tube through the large hole in the upper bracket. Remove the bung from the tube. The spring now inflates until its top plate comes into contact with the upper bracket of the air assist kit—Figures 15 and 16
3. Attach the top plate of the air spring to the upper bracket using two M8 x 16 bolts and two M8 washers. Once again, do not fully tighten the bolts as yet.

Final steps...

Once you have...

- inflated the springs—see Section 4.7
- attained the desired ride height for the vehicle
- aligned the springs—see Section 4.8

...tighten the four bolts that attach the springs to the brackets

Ford Transit 80/120 L.TRA.VA.C.M

4.5 Fitting of Inflator Console

Option Valves



Option 1

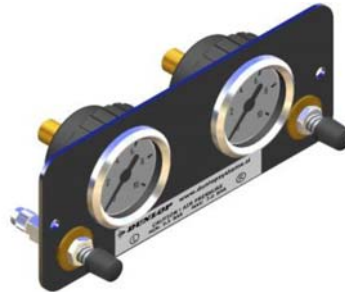

Option 2



Option 3



Your kit is supplied with one of the inflator console options shown above...

- 'Option Valves', having two valves and a bracket (above, top-left)
- 'Option 1', 'Option 2' or 'Option 3', having both valves and pressure gauges

Mount the console in a position of your choice whereby it is firmly fixed, has some protection from the environment (particularly important for the console with gauges) and is easily accessible. Suggested possible locations include...

Console with Valves Only...

- on the rear bumper
- at the rear beside the license plate
- on the chassis next to a rear wheel
- in a service shutter
- beside the fuel cap

Console with Valves and Gauges...

- in the vehicle cabin, within reach and sight of the driver
- in the wall of a cupboard (motorhomes)
- in a service shutter

'Comfort' Packages

The 'Option 2' and 'Option 3' panels, as shown above, are each part of a *Comfort Package* that is supplied with a compressor (and also an air reservoir in the case of the 'Option 3' panel) for ease of spring inflation and ride height setting. For further information please ask your dealer.

Ford Transit 80/120 L.TRA.VA.C.M

4.6 Tube Connection and Disconnection, Cutting and Routing

Connection and Disconnection

Tubes are connected as shown by the diagrams below...

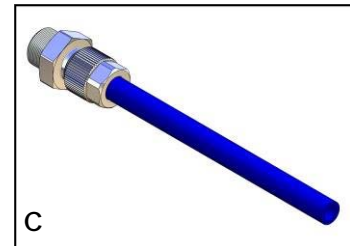
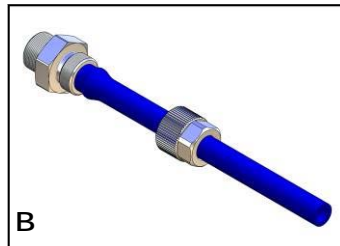
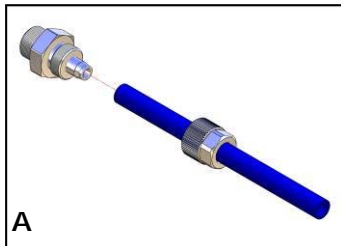

- Slide a nut over the end of the tube
- Push the tube onto the connector as far as possible
- Feed the nut up to the connector, fully tighten by hand and finally tighten one additional turn using spanners

Cutting

To achieve good sealing and air-tight fitting of tube ends to their connecting parts, it is very important to cut tubing cleanly and squarely. A dedicated guillotine action tubing cutter is recommended, or a craft knife if such a tool is not available. Do not use electrician's side cutters.



A dedicated tubing cutter -
Recommended



Electrician's Side Cutters
NOT Recommended



Ford Transit 80/120 L.TRA.VA.C.M

Routing

Study the underside of the vehicle and decide how to route each branch of the air circuit...

- To minimise the risk of chafing, avoid running tubing over metal edges as much as possible
- Avoid close proximity to heat sources such as the exhaust assembly
- Choose a route that provides as much protection as possible from dirt, debris and any solid objects that may impact the underside of the vehicle

It is recommended that tubes are guided alongside brake lines as much as possible.



Use cable ties ('tie wraps') to secure tubing to the chassis, taking care not to over-tighten them.

4.7 Spring Inflation

Once installation of the air assist kit is complete, inflate the springs via the inflator console taking careful note of the following...



Maximum and Minimum Pressure

Maximum Pressure 7.0bar **Minimum Pressure 0.5bar**

Do not exceed 7.0bar (101psi), which is the recommended maximum charge pressure for the air springs.

The springs may be deflated if the vehicle is to be stored for a lengthy period without use, but a pressure of at least 0.5bar (7.25psi) should be maintained at all times in order to avoid possible compression damage to the springs.

Ford Transit 80/120 L.TRA.VA.C.M

4.8 Spring Alignment

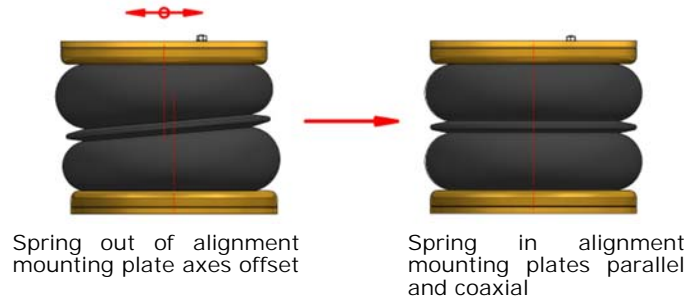

CAUTION!

Before fully tightening the bolts that secure the air spring to the upper and lower brackets, set the vehicle at ride height (spring height approximately 13.5cm) and ensure that the springs are correctly aligned.

4.9 Maintenance

Following installation, it is recommended that all metal parts are coated with a protective substance such as body wax.

The system does not require very much maintenance other than...

- ◆ to maintain air pressure in the springs. Much like a tyre, the system may lose a little air over time.
- ◆ to keep the air bellows clean. It is suggested that, when washing the vehicle, the bellows are inspected and cleaned as necessary (preferable by spraying). Look in particular for stones or grit trapped between convolutes, as this may damage the bellow.

Ford Transit 80/120
L.TRA.VA.C.M

5. INSTALLATION DIAGRAMS

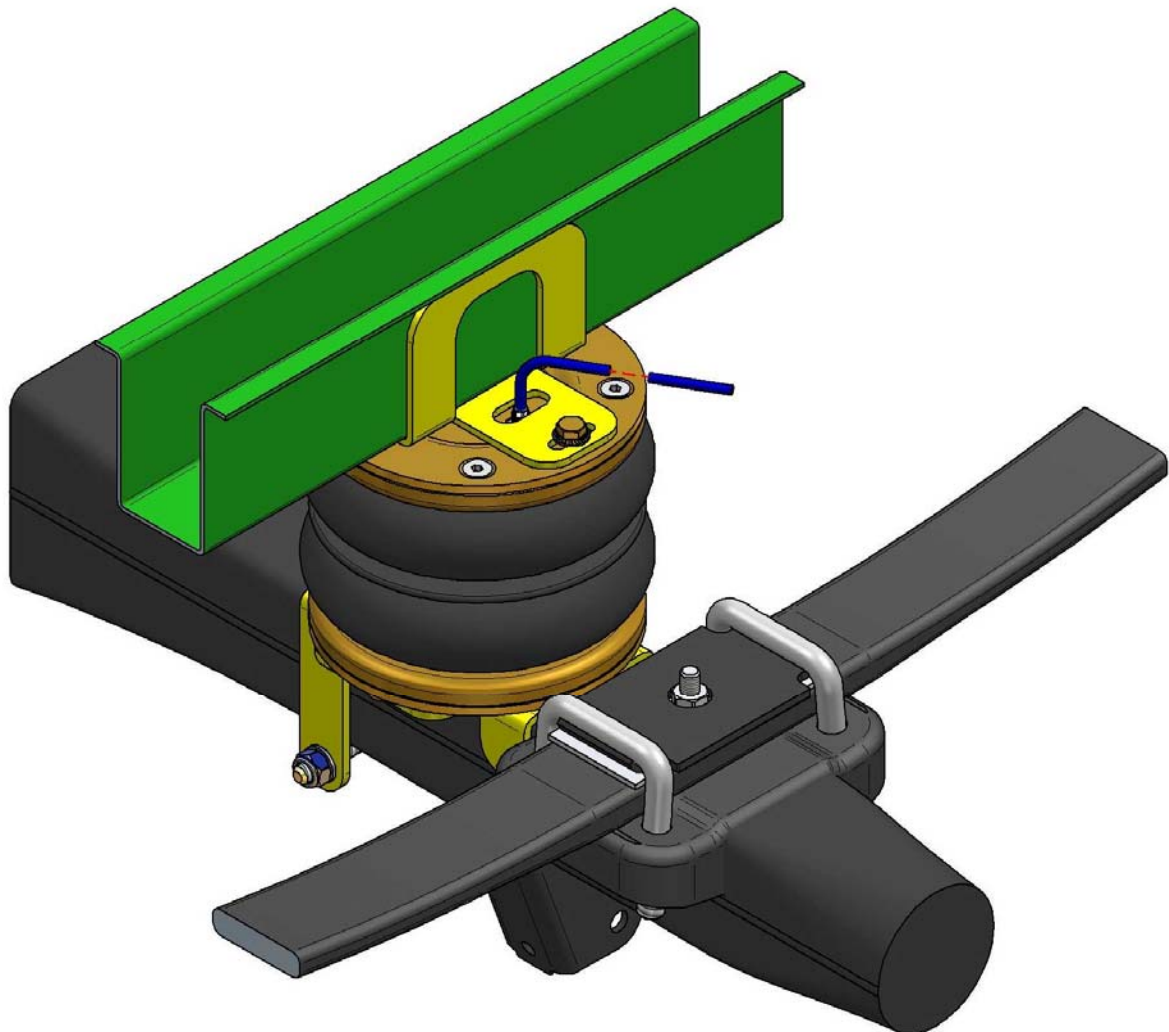

Ford Transit 80/120
L.TRA.VA.C.M

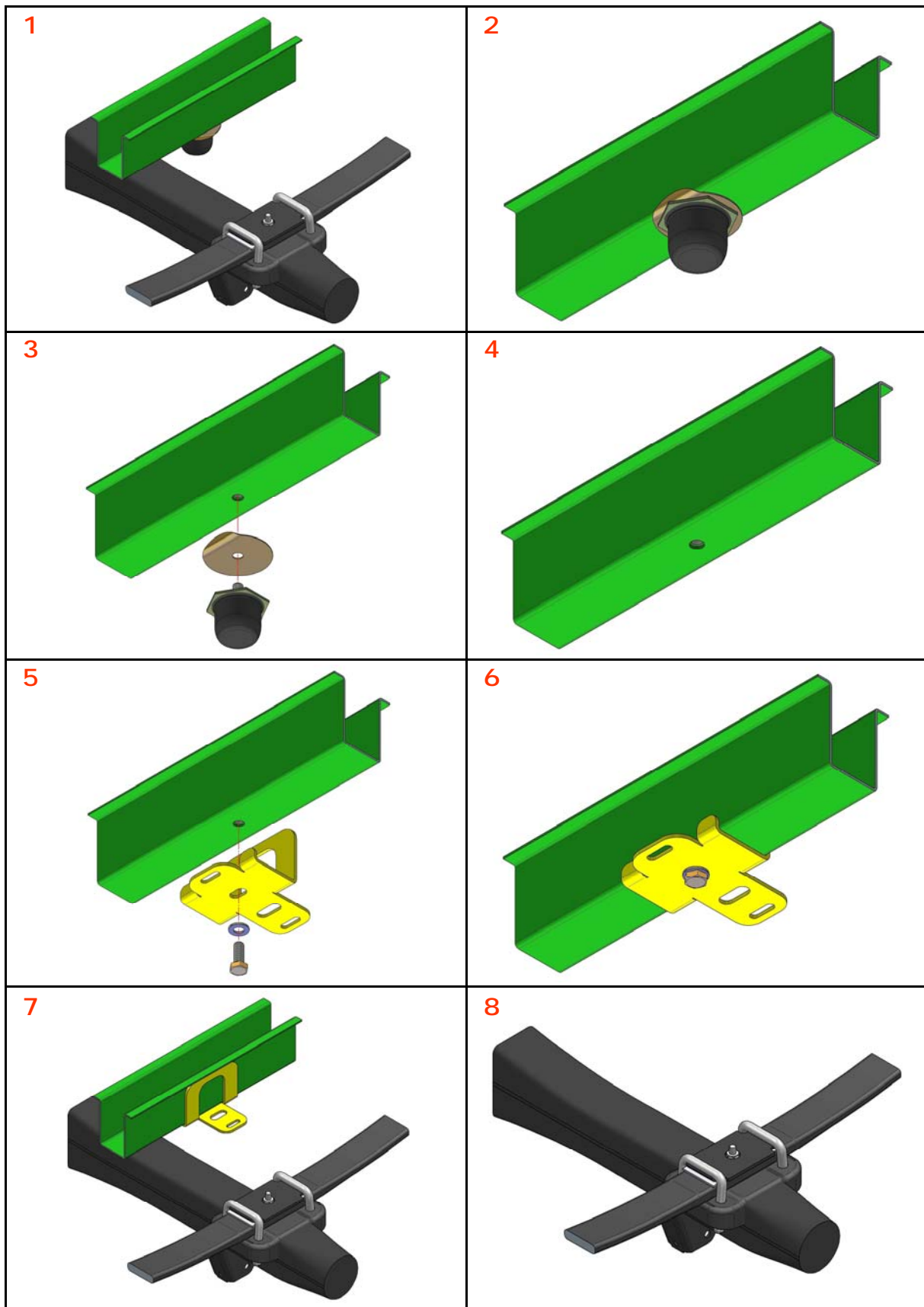

Ford Transit 80/120
L.TRA.VA.C.M

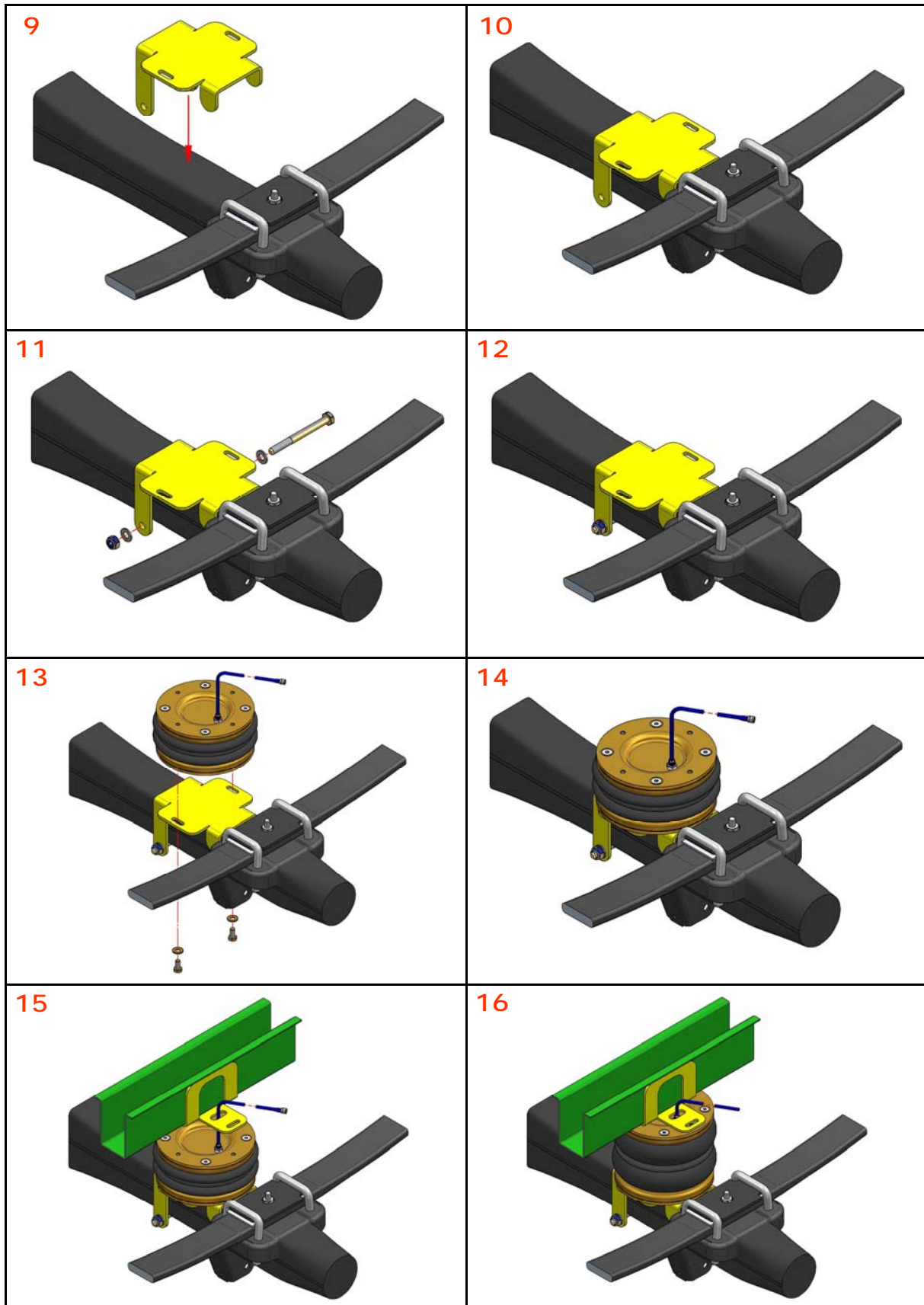

Ford Transit 80/120
L.TRA.VA.C.M

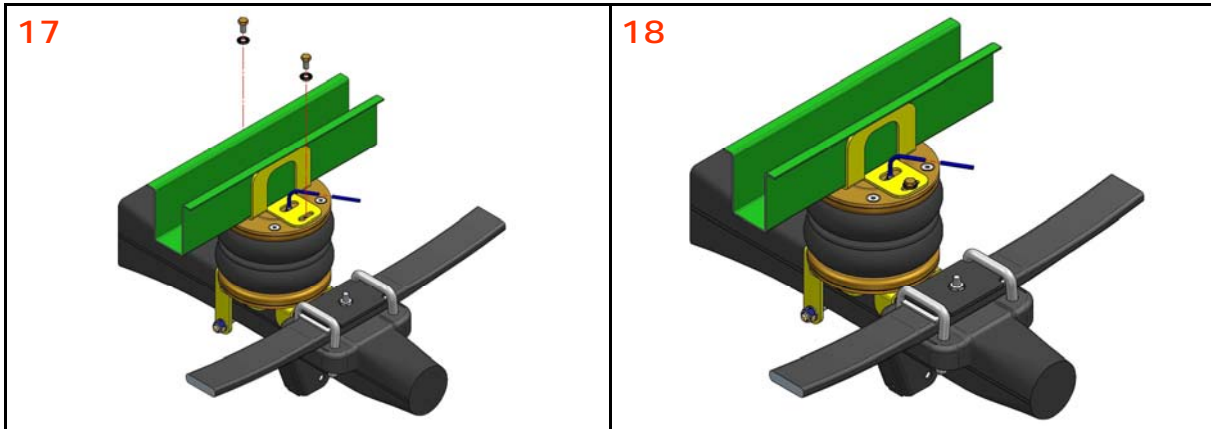



Ford Transit 80/120
L.TRA.VA.C.M

6. EPILOGUE

DSC Nederland hopes that you enjoy the benefits that your *DUNLOP* air suspension system will provide for you. To ensure optimal performance, we advise that you have your system checked frequently by qualified personnel. As recommended in the fitting instructions, it is important to coat all the steel parts with a protective substance such as body wax.

IMPORTANT : Manufacturer's Declaration Form

A manufacturer's declaration form is provided with your kit. Following installation of the kit please ensure that this form is completed, signed by a qualified fitter and a copy is returned to DSC Nederland by post, fax or e-mail. Our e-mail address is: info@dunlopsystems.nl

As a condition of your warranty, modifications to the system may only be carried out by personnel of DSC Nederland.

Enquiries

For general enquiries please contact one of our dealers. You can find them on our website.

www.dunlopsystems.nl

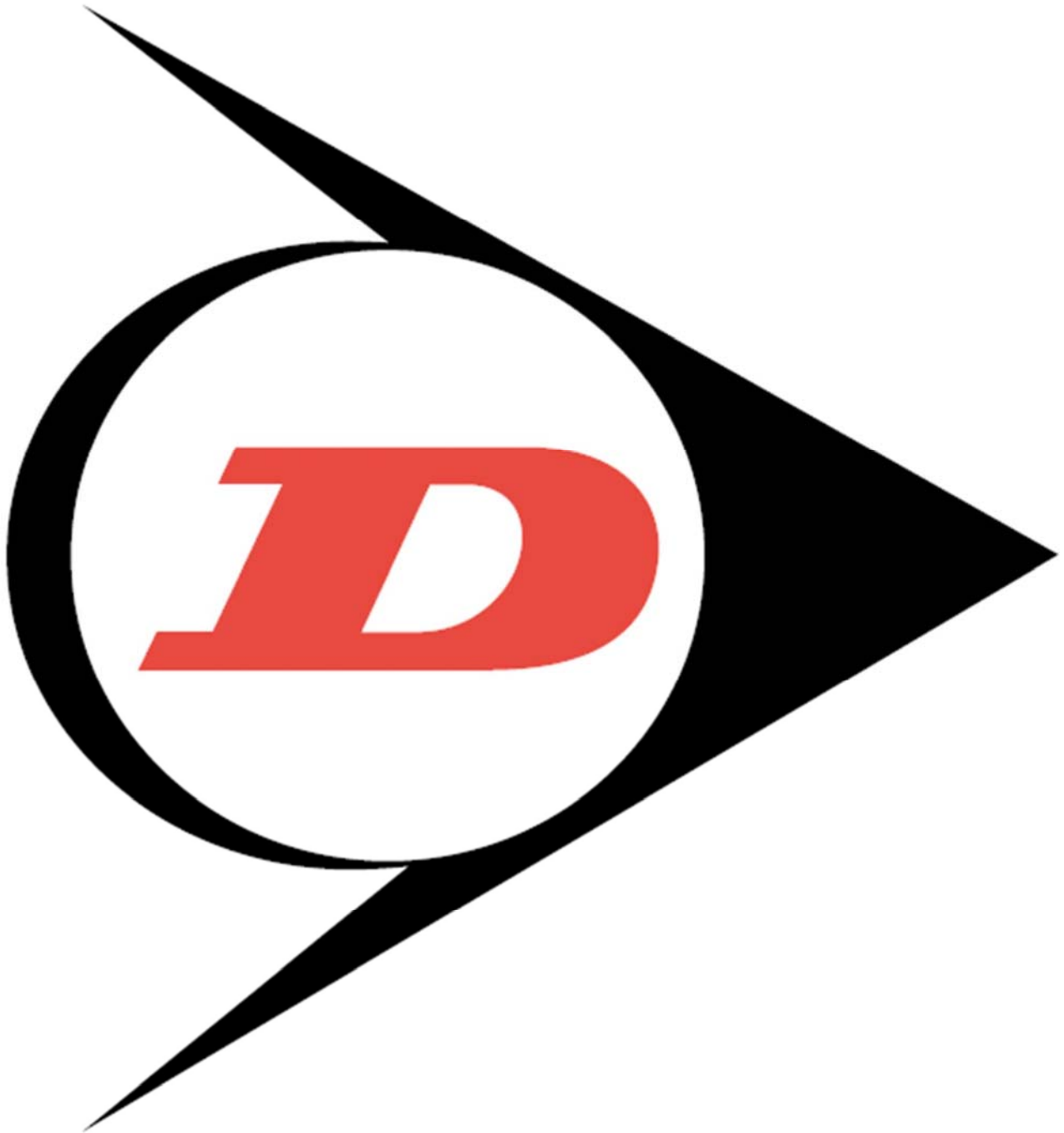

DSC Nederland B.V.
Het Wegdam 22
7496 CA Hengevelde
Nederland
Tel. : +31 (0)547 333065
Fax. : +31 (0)547 333068
e-mail: info@dunlopsystems.nl

www.dunlopsystems.nl