

Installation Manual

L.D84.C.M

Citroën Jumper / Relay X280/X290 (1984 - 1993)
Fiat Ducato X280/X290 (1984 - 1993)
Peugeot Boxer X280/X290 (1984 - 1993)





Citroën Jumper X280/X290

Fiat Ducato X280/X290

Peugeot Boxer X280/X290

L.D84.C.M

CONTENTS

1. FOREWORD	3
2. INTRODUCTION	4
3. VERY IMPORTANT NOTES	5
4. COMPLETE ASSEMBLY	7
5. INSTRUCTIONS FOR INSTALLATION.....	8
5.1. Bump Stop Removal and Fitting of Upper Bracket	8
5.2. Fitting of Lower Bracket.....	8
5.3. Fitting of Air Bellow.....	9
5.4. Fitting of Inflator Console	10
5.5. Tube Connection and Disconnection, Cutting and Routing.....	11
5.6. Spring Inflation	12
5.7. Spring Alignment.....	13
5.8. IMPORTANT! Load Sensing Valve (LSV) Adjustment.....	13
5.9. Maintenance	14
5.10. Installation Drawings.....	15
6. EPILOGUE	20

DSC Nederland B.V.
 Het Wegdam 22
 7496 CA Hengevelde
 Nederland
 Tel. : +31 (0)547 333065
 Fax. : +31 (0)547 333068
 e-mail: info@dunlopsystems.nl
 Website: www.dunlopsystems.nl

© 2017, DSC Nederland B.V.

**FIAT**

Citroën Jumper X280/X290

Fiat Ducato X280/X290

Peugeot Boxer X280/X290

L.D84.C.M

1. FOREWORD

This manual provides instructions for the installation of an auxiliary air suspension kit, developed specifically for the Citroën Jumper/Relay X280/X290 (C25), Fiat Ducato X280/X290 and Peugeot Boxer X280/X290 (J5). To ensure correct installation of the kit, it is strongly recommended that these instructions are read thoroughly before commencing any installation work. Installation should only be carried out by a suitably qualified mechanic or specialist installation facility. DSC Nederland will not accept any responsibility for faults or defects arising from incorrect installation, which automatically renders the guarantee invalid.

IMPORTANT : Manufacturer's Declaration Form

A manufacturer's declaration form is provided with your kit. Following installation of the kit please ensure that this form is completed, signed by a qualified fitter and a copy is returned to DSC Nederland by post, fax or e-mail. Our e-mail address is: info@dunlopsystems.nl

This kit is suitable for motorhomes and other vehicles with a minimum rear axle load of 1550kg (3417lbs).

**FIAT**

Citroën Jumper X280/X290

Fiat Ducato X280/X290

Peugeot Boxer X280/X290

L.D84.C.M

2. INTRODUCTION

Thank you for choosing an auxiliary air suspension kit from the range offered by *DSC Nederland*. Auxiliary air suspension is fitted in tandem with the standard steel springs of the vehicle suspension, and provides enhancements in terms of both the stability of the vehicle and the comfort of the passengers...

Vehicle Levelling

Simply by varying the air pressure in the springs, the vehicle can be levelled both front-to-rear and side-to-side. Keeping the vehicle level optimises stability, ensures correct headlamp beam distribution and reduces tyre wear arising from uneven distribution of weight.

Straight Line Stability

Straight line stability is greatly increased at higher speeds, and when subjected to buffeting from cross-winds or large overtaking vehicles

Reduced Body Roll

Body roll when cornering or negotiating roundabouts is significantly reduced.

Fatigue Reduction and Wear Compensation

Suspension fatigue is reduced, so helping to prevent leaf springs from sagging under repeated or constant loading. Any sagging already present can be compensated-for. This is a particular benefit for motorhomes, which are always fully laden.

Ride Comfort

Air springs help to absorb shock loads from uneven road surfaces, therefore general ride quality is much improved.

**FIAT**

Citroën Jumper X280/X290

Fiat Ducato X280/X290

Peugeot Boxer X280/X290

L.D84.C.M

3. VERY IMPORTANT NOTES



Gross Vehicle Weight (GVW)

Air assist kits are not in themselves designed to increase the gross vehicle weight (GVW) rating of a vehicle. They do not legally allow for carriage of a load greater than the carrying capacity stated on the data plate of the vehicle.

Do not exceed the maximum load specified by the vehicle manufacturer...

- ◆ to avoid compromising passenger safety
- ◆ to prevent possible damage to the vehicle
- ◆ for legal reasons



Load Sensing Valve (LSV) Adjustment

If your vehicle is not fitted with an antilock braking system (ABS) then it will have a load sensing valve (LSV) to automatically adjust braking force under varying load conditions. This valve **must** be adjusted immediately after the fitting of an air assist kit and before the vehicle is driven again on public roads.

If the LSV is not adjusted following the fitting of an air assist kit, it may misjudge rear load conditions to the extent that the braking pressure applied to the rear brakes is not correct (e.g. the rear wheels may lock with no load on the rear axle). The consequences of this in terms of vehicle stability and safety are potentially serious.

Vehicle Upgrading

Despite the above words of caution, it is possible to upgrade the weight rating of your vehicle. This must be carried-out by a specialist supplier that will...

- ◆ carry out any necessary modifications in addition to fitting the air assist kit
- ◆ complete documentation as necessary to inform the Vehicle and Operator Services Agency (VOSA) – a mandatory requirement
- ◆ supply and fit a new weight plate to replace the original plate supplied with the vehicle

This process applies to United Kingdom registered vehicles. The process in other countries may be different.



FIAT



Citroën Jumper X280/X290

Fiat Ducato X280/X290

Peugeot Boxer X280/X290

L.D84.C.M

Safety Guidance Note

The following very useful guidance note is available for free download from the *Health and Safety Executive* (HSE)...

PM85, July 2007 *Safe recovery (and repair) of buses and coaches fitted with air suspension*

The uniform resource locator (URL) for this document is...

<http://www.hse.gov.uk/PUBNS/pm85.pdf>



Citroën Jumper X280/X290

Fiat Ducato X280/X290

Peugeot Boxer X280/X290

L.D84.C.M

4. COMPLETE ASSEMBLY

The complete assembly is shown by the diagrams below...

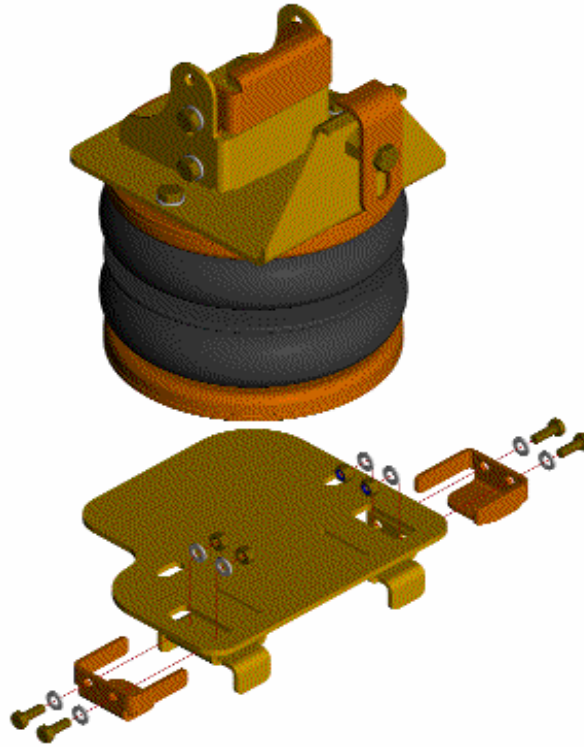

Figure 1(a). Bellow and Brackets

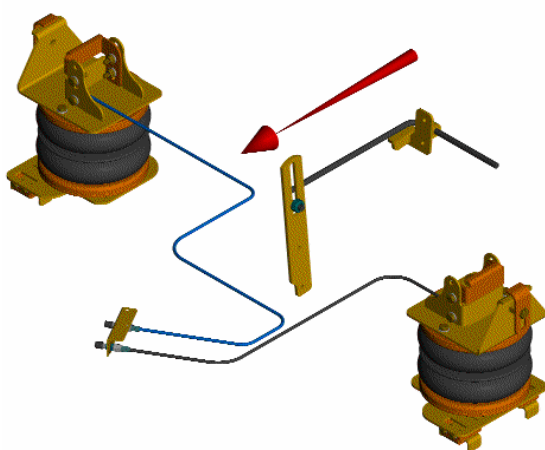

Figure 1(b)
Configuration for vehicle with standard bump stop

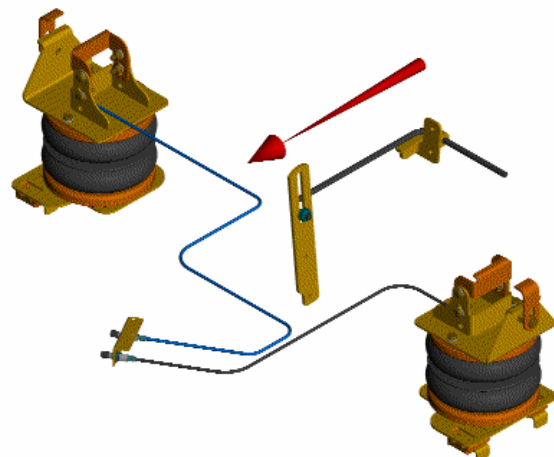

Figure 1(c)
Configuration for vehicle with lowered bump stop

Figures 1(b) and (c) above illustrate that the upper air spring brackets of your kit are adjustable according to whether your vehicle is fitted with a standard bump stop (1(b)) or a lowered bump stop (1(c)).

**FIAT**

Citroën Jumper X280/X290

Fiat Ducato X280/X290

Peugeot Boxer X280/X290

L.D84.C.M

5. INSTRUCTIONS FOR INSTALLATION



Preparation and Precaution

Before beginning installation, ensure that you have sufficient clearance between the axle and the chassis. Use a jack if necessary. Install at one side of the vehicle at a time.



Pay attention to your safety at all times during installation - always use axle stands to support the vehicle!



The following instructions make reference to the diagrams on pages 16 to 19 inclusive.

5.1 Bump Stop Removal and Fitting of Upper Bracket

- i. Remove the bump stop by prizing it away from its mount— Figures 1 and 2. One of the two holes vacated by removal of the bump stop will be used for attachment of the upper bracket.
- ii. Choose the correct holes to attach the small flange bracket. Use the four M8 x 20 bolts, eight washers and four self locking nuts—Figures 3 and 4.
- iii. Attach the upper bracket to the chassis, such that the lower flange of the bracket presses against the lower part of the chassis rail—Figures 3 to 5. It is likely that you will need to loosen the two bolts that hold together the two slidable parts of the bracket and then re-tighten them once the bracket is in place against the chassis.
- iv. The upper bracket has a nut welded to it to which the small L-shaped bracket is attached. Attach this small bracket such that its 'lip' part is over the seam of the chassis, use the M8 x 20 bolt, washer and spring washer to secure —Figures 6 and 7.

5.2 Fitting of Lower Bracket

The lower bracket is attached directly beneath the upper bracket, making use of two flanges built on to the axle with which the bump stop would have been in contact when the vehicle suspension was in its compressed ('bump') position— Figure 8.

- i. Place the lower bracket in position against the axle—Figures 9 and 10
- ii. Secure the lower bracket to the axle flanges using the two small U-shaped brackets, by using four M6 x 20 bolts, eight washers and four self locking nuts—Figures 11 and 12

**FIAT**

Citroën Jumper X280/X290

Fiat Ducato X280/X290

Peugeot Boxer X280/X290

L.D84.C.M

5.3 Fitting of Air Bellow

- i. See Section 5.5 - "*Tube Connection and Disconnection, Cutting and Routing*" : Connect a tube to the bellow by pushing the tube into the air inlet port on the underside of the spring and then hand-rotating the tube by one screw turn. Use black tubing for the left-hand bellow and blue for the right-hand bellow. Feed the tube through the hole in the upper bracket.
- ii. Place the bellow into position between the upper and lower brackets—Figures 14 and 15
- iii. Attach the bellow to the upper bracket using two M8 x 16mm bolts and two disc spring washers—Figure 16. Do not fully tighten the bolts at this stage because the bellow may require alignment once inflated (Section 5.7).
- iv. Attach the bellow to the lower bracket using two M8 x 16mm bolts and two disc spring washers—Figure 16. Do not fully tighten the bolts at this stage because the bellow may require alignment once inflated (Section 5.7).

**FIAT**

PEUGEOT



Citroën Jumper X280/X290

Fiat Ducato X280/X290

Peugeot Boxer X280/X290

L.D84.C.M

5.4 Fitting of Inflator Console

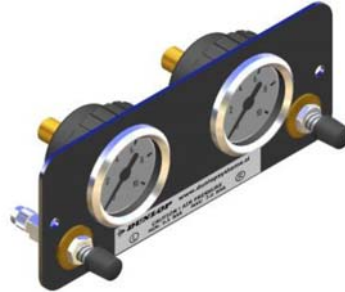
Option Valves**Option 1****Option 2****Option 3**

Your kit is supplied with one of the inflator console options shown above...

- 'Option Valves', having two valves and a bracket (above, top-left)
- 'Option 1', 'Option 2' or 'Option 3', having both valves and pressure gauges

Mount the console in a position of your choice whereby it is firmly fixed, has some protection from the environment (particularly important for the console with gauges) and is easily accessible. Suggested possible locations include...

Console with Valves Only...

- on the rear bumper
- at the rear beside the license plate
- on the chassis next to a rear wheel
- in a service shutter
- beside the fuel cap

Console with Valves and Gauges...

- in the vehicle cabin, within reach and sight of the driver
- in the wall of a cupboard (motorhomes)
- in a service shutter

'Comfort' Packages

The 'Option 2' and 'Option 3' panels, as shown above, are each part of a *Comfort Package* that is supplied with a compressor (and also an air reservoir in the case of the 'Option 3' panel) for ease of spring inflation and ride height setting. For further information please ask your dealer.



FIAT



Citroën Jumper X280/X290

Fiat Ducato X280/X290

Peugeot Boxer X280/X290

L.D84.C.M

5.5 Tube Connection and Disconnection, Cutting and Routing

Connection and Disconnection

Tubes are connected as shown by the diagrams below...

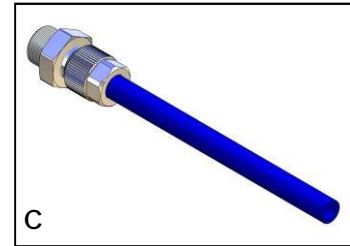
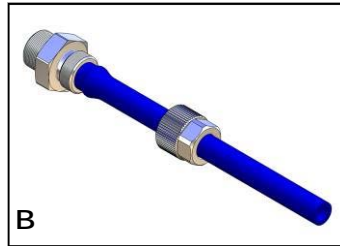
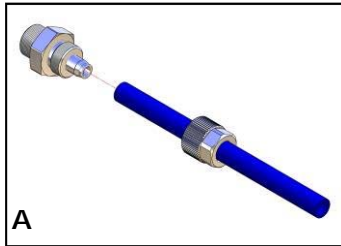

- A. Slide a nut over the end of the tube
- B. Push the tube onto the connector as far as possible
- C. Feed the nut up to the connector, fully tighten by hand and finally tighten one additional turn using spanners
- D. Take care the hose won't twist

Cutting

To achieve good sealing and air-tight fitting of tube ends to their connecting parts, it is very important to cut tubing cleanly and squarely. A dedicated guillotine action tubing cutter is recommended, or a craft knife if such a tool is not available. Do not use electrician's side cutters.



A dedicated tubing cutter -
Recommended



Electrician's Side Cutters
NOT Recommended

**FIAT**

Citroën Jumper X280/X290

Fiat Ducato X280/X290

Peugeot Boxer X280/X290

L.D84.C.M

Routing

Study the underside of the vehicle and decide how to route each branch of the air circuit...

- To minimise the risk of chafing, avoid running tubing over metal edges as much as possible
- Avoid close proximity to heat sources such as the exhaust assembly
- Choose a route that provides as much protection as possible from dirt, debris and any solid objects that may impact the underside of the vehicle

It is recommended that tubes are guided alongside brake lines as much as possible.



Use cable ties ('tie wraps') to secure tubing to the chassis, taking care not to over-tighten them.

5.6 Spring Inflation

Once installation of the air assist kit is complete, inflate the springs via the inflator console taking careful note of the following...



Maximum and Minimum Pressure

Maximum Pressure 7.0bar **Minimum Pressure 0.5bar**

Do not exceed 7.0bar (101psi), which is the recommended maximum charge pressure for the air springs.

The springs may be deflated if the vehicle is to be stored for a lengthy period without use, but a pressure of at least 0.5bar (7.25psi) should be maintained at all times in order to avoid possible compression damage to the springs.

**FIAT**

Citroën Jumper X280/X290

Fiat Ducato X280/X290

Peugeot Boxer X280/X290

L.D84.C.M

5.7 Spring Alignment

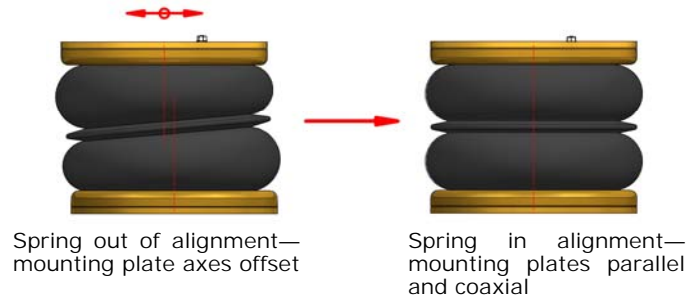

CAUTION!

Before fully tightening the bolts that secure the air spring to the upper and lower brackets, set the vehicle at ride height (spring height approximately 14cm) and ensure that the springs are correctly aligned.

5.8 **IMPORTANT!** Load Sensing Valve (LSV) Adjustment

Once the auxiliary air suspension system is installed and the bellows are inflated such that the desired vehicle ride height is achieved, the LSV assembly must be modified—see Figures 19 to 29 inclusive. This involves fitting two brackets, as supplied in your kit, to the existing assembly.

- i. Detach and remove the upper of the two interconnected brackets—Figures 19 to 22 inclusive
- ii. Detach the LSV rod hinge from its supporting bracket—Figure 23
- iii. Mate the adaptor bracket to the hinge-supporting bracket and then reattach the hinge—Figures 24 and 25
- iv. Attach the slotted bracket supplied to the existing LSV axle bracket, with the exposed end of the LSV rod through the slot in the bracket—Figures 26 and 27
- v. Secure the exposed end of the LSV rod to the slotted bracket by push-fitting the clamping ring provided—Figures 28 and 29

**FIAT**

Citroën Jumper X280/X290

Fiat Ducato X280/X290

Peugeot Boxer X280/X290

L.D84.C.M

5.9 Maintenance

Following installation, it is recommended that all metal parts are coated with a protective substance such as body wax.

The system does not require very much maintenance other than...

- ♦ to maintain air pressure in the springs. Much like a tyre, the system may lose a little air over time.
- ♦ to keep the air bellows clean. It is suggested that, when washing the vehicle, the bellows are inspected and cleaned as necessary (preferable by spraying). Look in particular for stones or grit trapped between convolutes, as this may damage the bellow.



FIAT



Citroën Jumper X280/X290

Fiat Ducato X280/X290

Peugeot Boxer X280/X290

L.D84.C.M

5.10 Installation Drawings

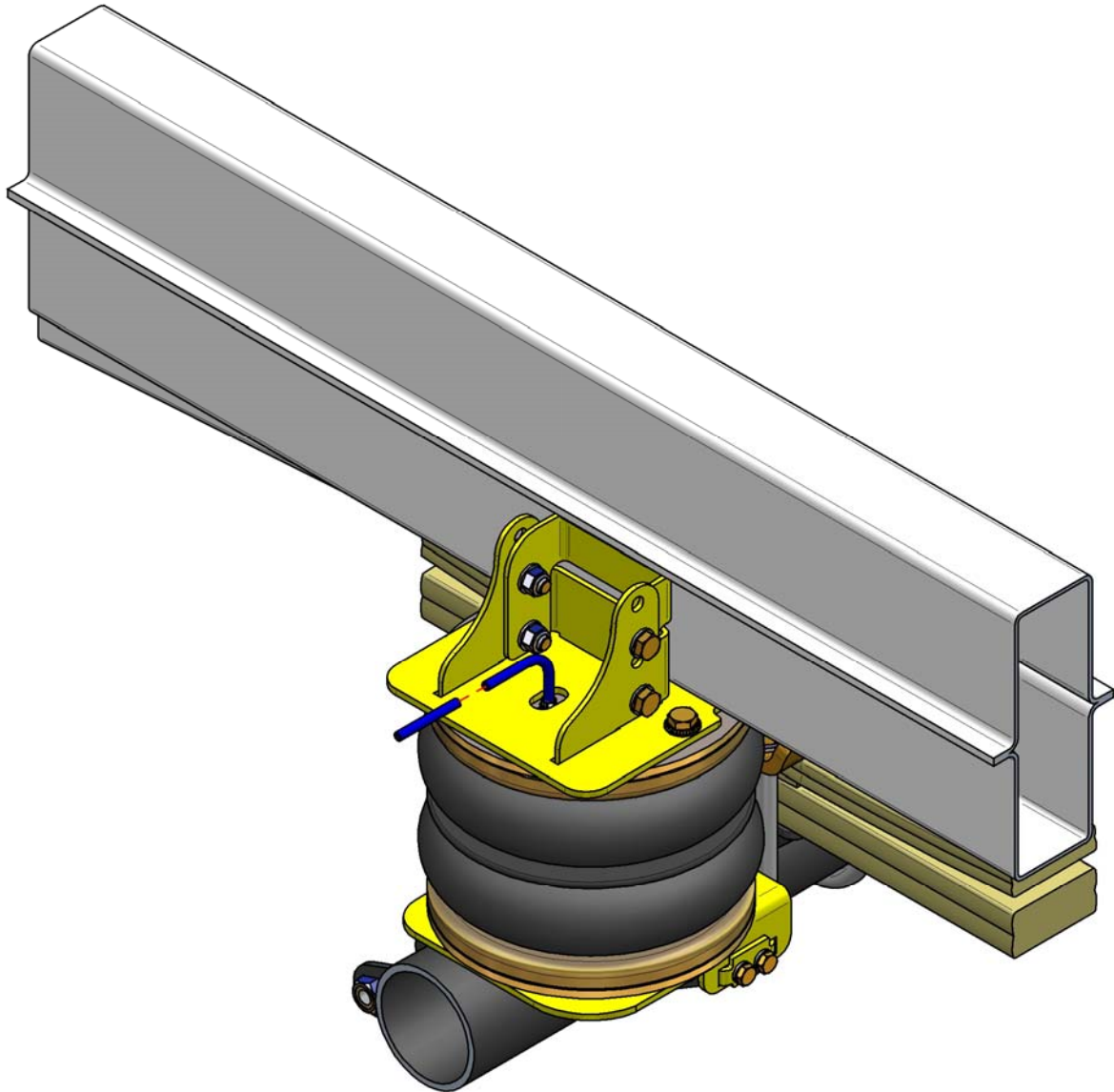



FIAT



Citroën Jumper X280/X290

Fiat Ducato X280/X290

Peugeot Boxer X280/X290

L.D84.C.M

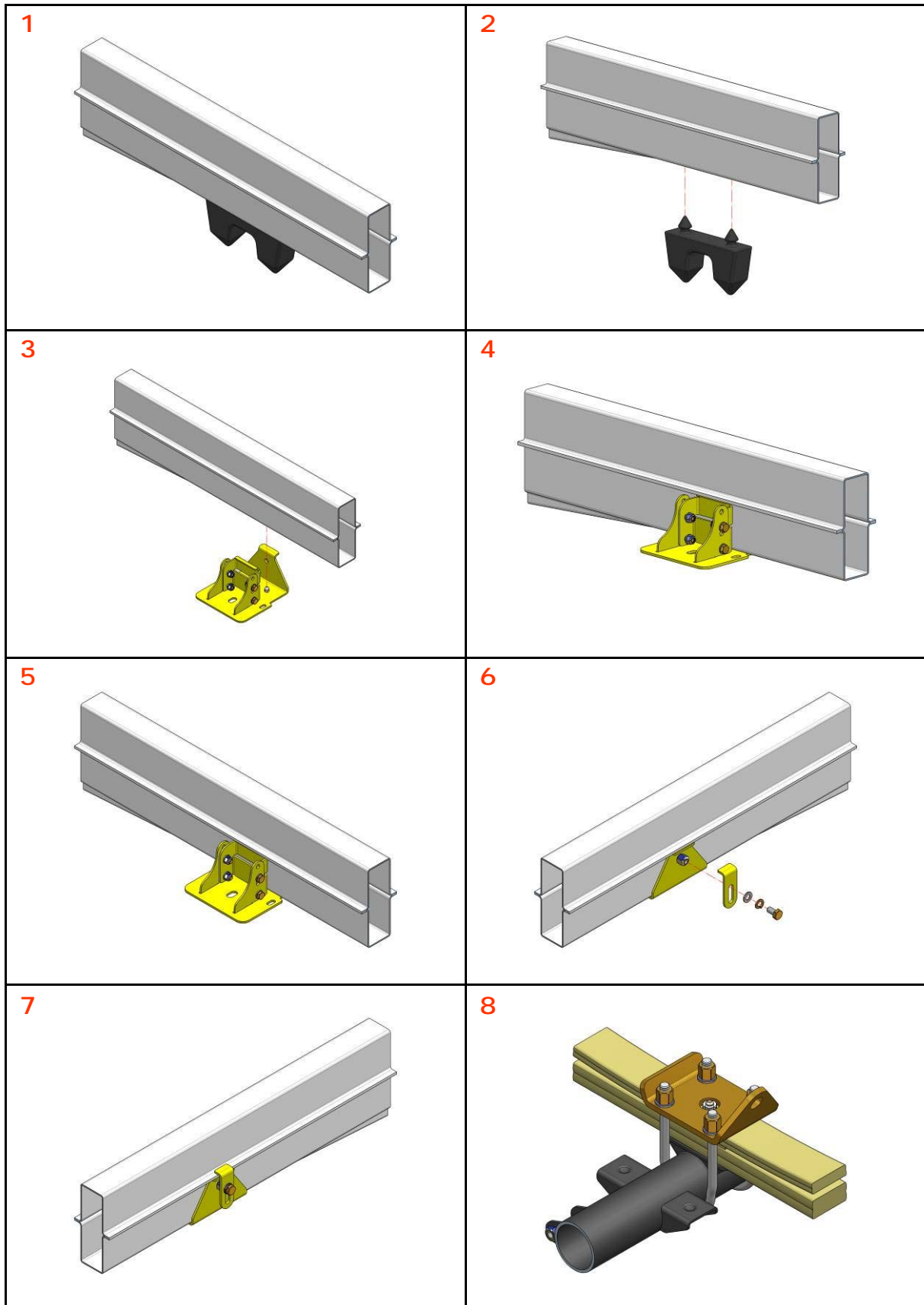



Citroën Jumper X280/X290

Fiat Ducato X280/X290

Peugeot Boxer X280/X290

L.D84.C.M

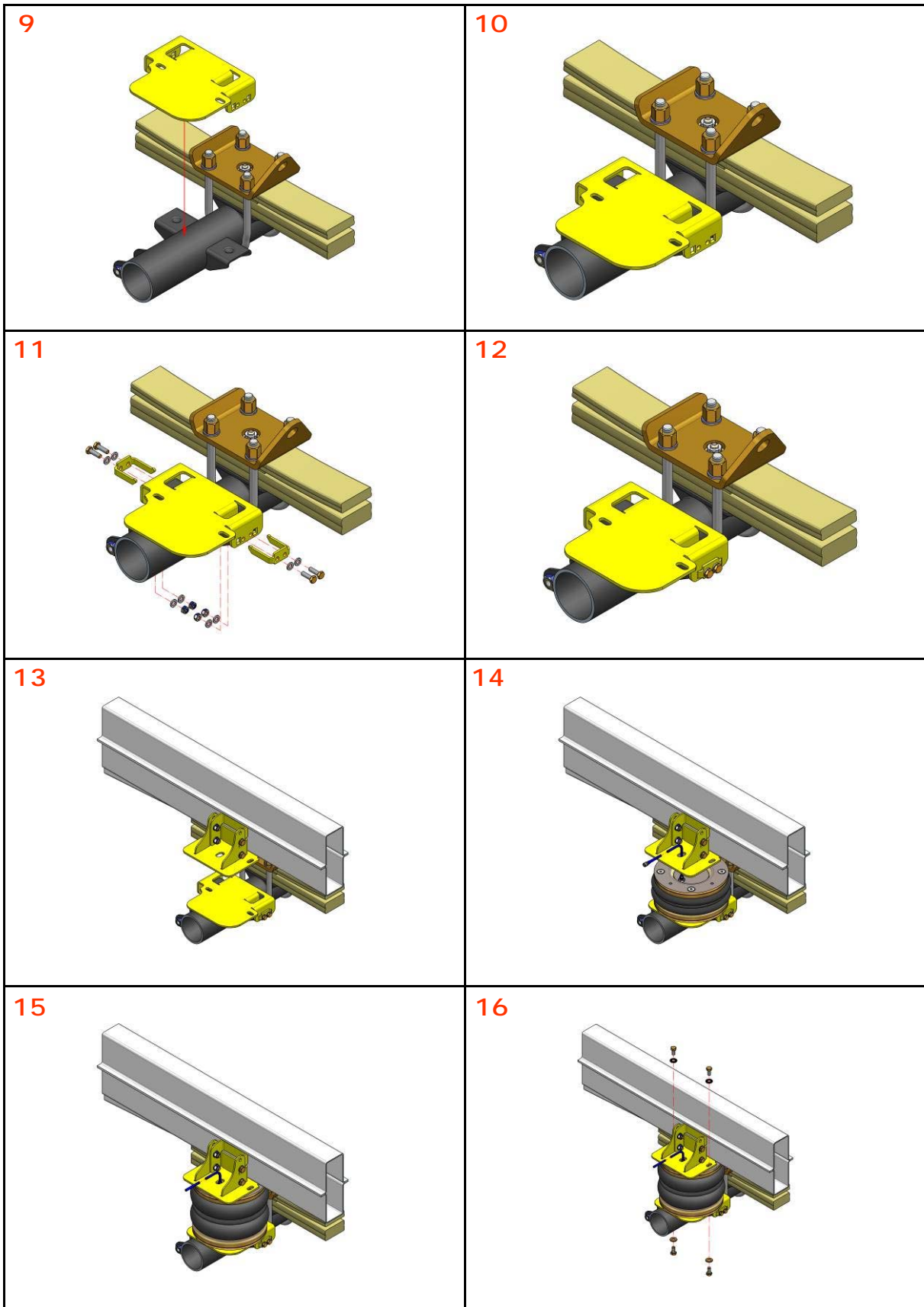



Citroën Jumper X280/X290

Fiat Ducato X280/X290

Peugeot Boxer X280/X290

L.D84.C.M

<p>17</p>	<p>18</p> <p>Spring out of alignment—mounting plate axes offset</p> <p>Spring in alignment—mounting plates parallel and coaxial</p> <p>CAUTION! Before fully tightening the bolts that secure the air spring to the upper and lower brackets, set the vehicle at ride height (spring height approximately 13.5cm) and ensure that the springs are correctly aligned.</p>
<p>19</p>	<p>20</p>
<p>21</p>	<p>22</p>
<p>23</p>	<p>24</p>



FIAT



Citroën Jumper X280/X290

Fiat Ducato X280/X290

Peugeot Boxer X280/X290

L.D84.C.M

25

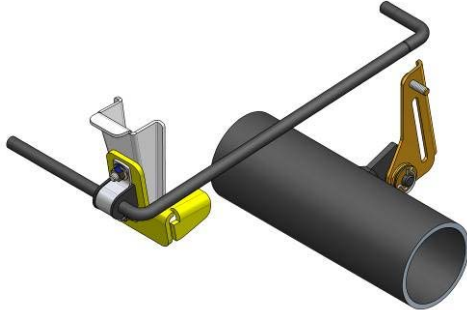

26

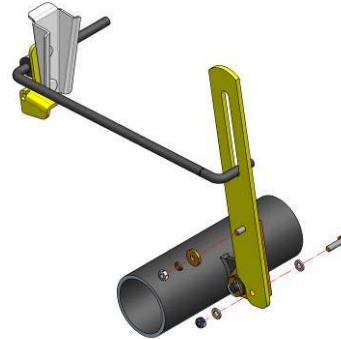

27

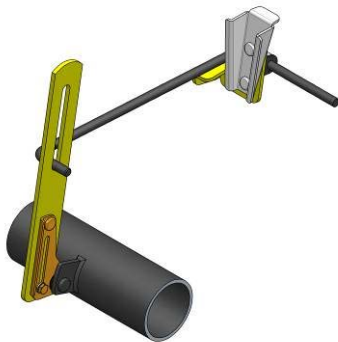

28

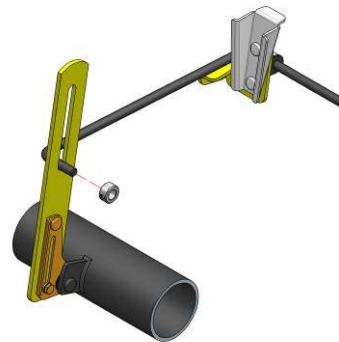

29

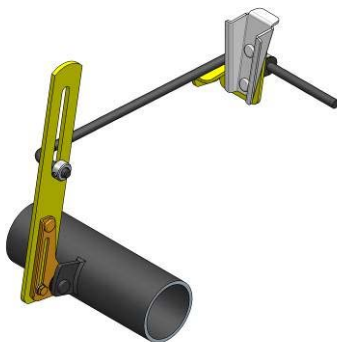

**FIAT**

Citroën Jumper X280/X290

Fiat Ducato X280/X290

Peugeot Boxer X280/X290

L.D84.C.M

6. EPILOGUE

DSC Nederland hopes that you enjoy the benefits that your *DUNLOP* air suspension system will provide for you. To ensure optimal performance, we advise that you have your system checked frequently by qualified personnel. As recommended in the fitting instructions, it is important to coat all the steel parts with a protective substance such as body wax.

IMPORTANT : Manufacturer's Declaration Form

A manufacturer's declaration form is provided with your kit. Following installation of the kit please ensure that this form is completed, signed by a qualified fitter and a copy is returned to DSC Nederland by post, fax or e-mail. Our e-mail address is: info@dunlopsystems.nl

As a condition of your warranty, modifications to the system may only be carried out by personnel of DSC Nederland.

Enquiries

For general enquiries please contact one of our dealers. You can find them on our website.

www.dunlopsystems.nl

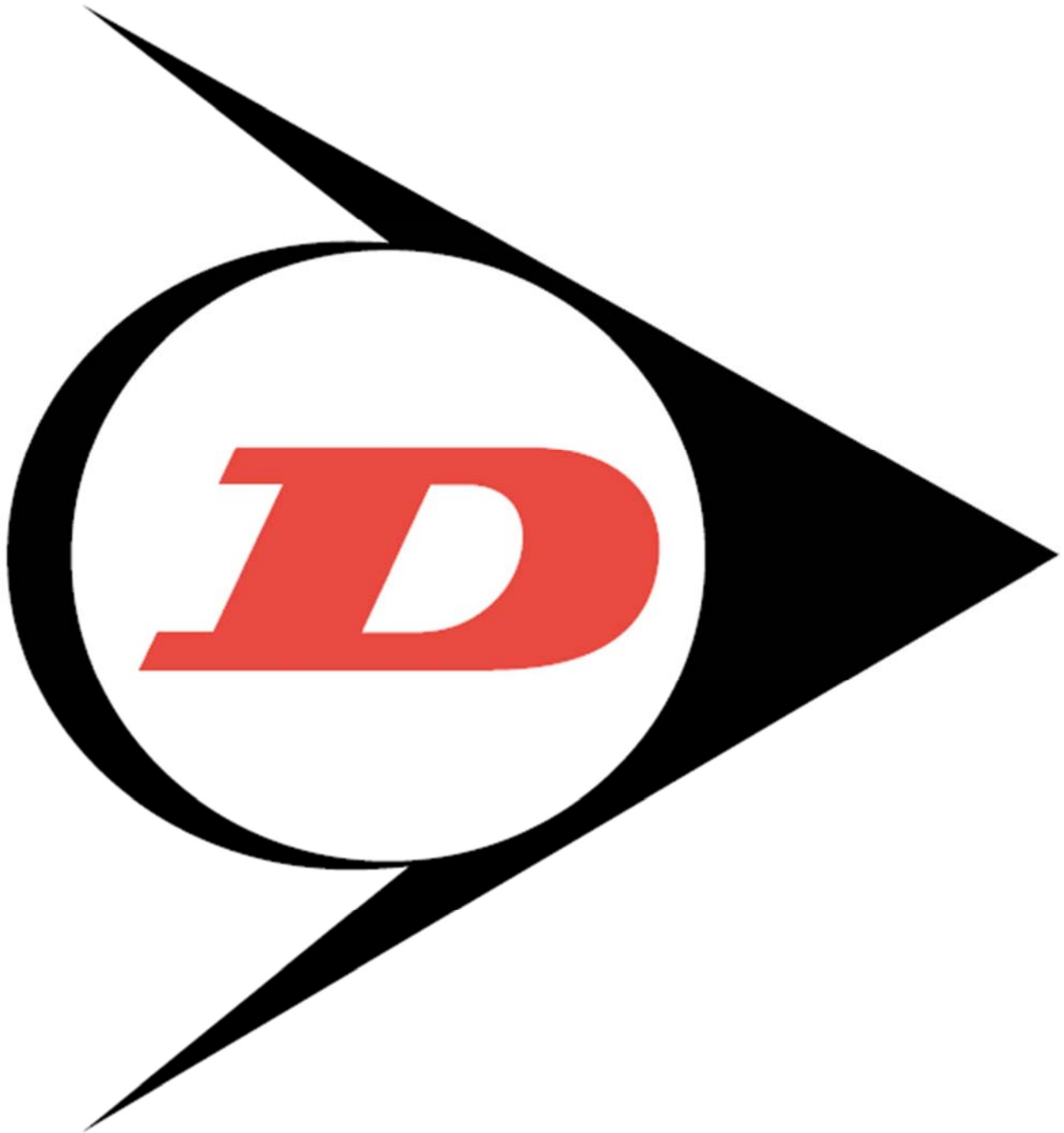

DSC Nederland B.V.
Het Wegdam 22
7496 CA Hengevelde
Nederland
Tel. : +31 (0)547 333065
Fax. : +31 (0)547 333068
e-mail: info@dunlopsystems.nl

www.dunlopsystems.nl